



INSTRUCTION BOOKLET

SUPER NINTENDO
ENTERTAINMENT SYSTEM

WARNING: PLEASE CAREFULLY READ THE CONSUMER INFORMATION AND PRECAUTIONS BOOKLET INCLUDED WITH THIS PRODUCT BEFORE USING YOUR NINTENDO® HARDWARE SYSTEM, GAME PAK OR ACCESSORY.



This official seal is your assurance that Nintendo has reviewed this product and that it has met our standards for excellence in workmanship, reliability and entertainment value. Always look for this seal when buying games and accessories to ensure complete compatibility with your Nintendo product.

All Nintendo products are licensed by sale for use only with other authorized products bearing the Official Nintendo Seal of Quality.™

Thank you for selecting this Mario Paint™ set for your Super Nintendo Entertainment System®

Please read this instruction manual thoroughly to ensure maximum enjoyment of your Mario Paint game pak. Please refer to the Super NES Mouse™ instruction manual for information about the Super NES Mouse and Mouse Pad.



TM & ® are trademarks of Nintendo
©1992 Nintendo

T A B L E O F C O N T E N T S

| | PAGE |
|---|------|
| 1. Basic Functions and Operations | 3 |
| 2. How to use your Mario Paint set with your Super NES | 4 |
| 3. Title Screen | 4 |
| 4. Drawing Board | 5 |
| 5. Icon Introduction | 6 |
| 6. Drawing Tools | 7 |
| 7. Utilities | 16 |
| 8. Music Composition | 20 |
| 9. Animation | 22 |
| 10. Save, Load, and Coloring Book Features | 26 |
| 11. Gnat Attack™ | 29 |
| 12. Glossary | 32 |
| WARRANTY AND SERVICE INFORMATION | 34 |

1. Basic Functions and Operations

The Super NES Mouse has two primary operations that are used in Mario Paint. In this manual, the terms "click" and "drag" describe the following functions:

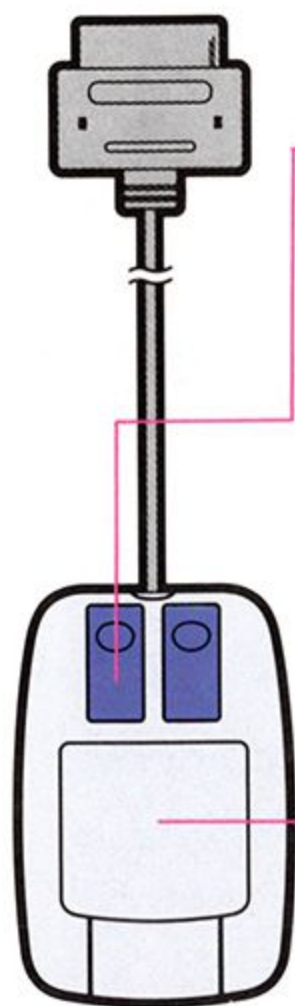

Click: Press the left mouse button, unless specifically instructed to press the right mouse button. Clicking the left mouse button will allow you to select various icons, advance through the color palette, and draw with the tools in Mario Paint. The right mouse button pauses the game in Gnat Attack and allows you to move backwards through the color palette.

Drag: Move the mouse across the mouse pad with the left mouse button pressed.

Refer to glossary on page 32 for descriptions of other unfamiliar terms.

2. How to use your Mario Paint set with your Super NES

■ The following instructions will help you get started.

1. Insert your Mario Paint game pak into the Super NES Control Deck.
2. Connect the plug from your Super NES Mouse into controller port #1 on the Super NES.
Do not plug anything in controller port #2.
3. Move the power switch on the control deck to the ON position.

3. Title Screen



Similar to a pencil, the Super NES Mouse follows the movements of your hand and moves the cursor on the screen.

On the title screen, you can move the cursor to the letters that spell "Mario Paint" and click on each letter.

This will help you get familiar with the play control of the mouse. What you find may surprise you!



★ Now you're ready to start! To enter the drawing area, click the cursor on Mario.

4. Drawing Board

■ **The Mario Paint drawing board has three main areas: the palette, the drawing toolbox, and the utility menu.**

The palette at the top of the screen lets you access 15 colors, 75 patterns, and 120 character stamps. To view the palette's fourteen pages, move the cursor to the upper right corner of the screen and click the left mouse button on Mr. Crayon. To move backwards through these pages, click the right mouse button on Mr. Crayon. The small window in the upper left corner displays the current color or stamp.

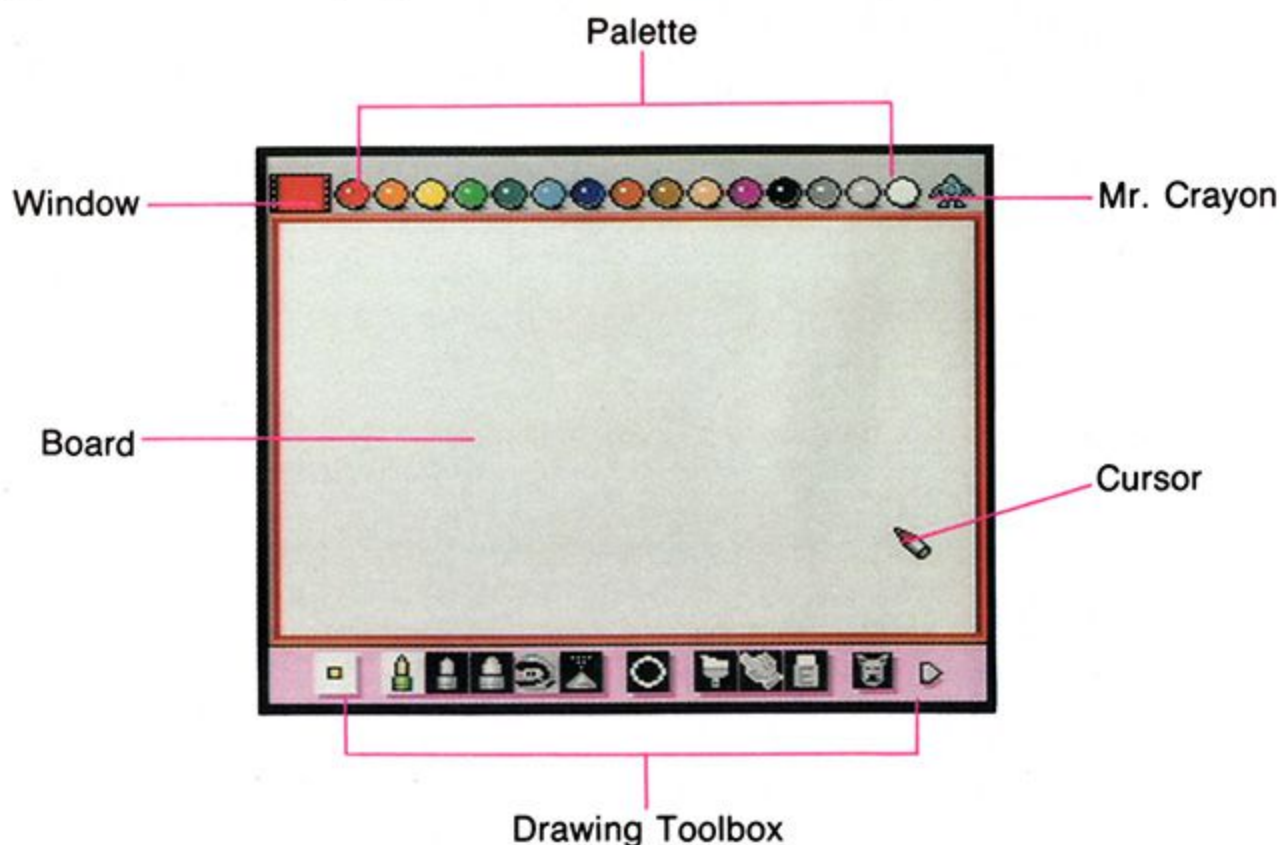

The drawing toolbox is the row of 11 icons on the bottom of the television screen. To access the utility menu, click on the arrow in the lower right corner. You'll notice that there are 10 more icons on this menu. We will cover each of these 21 functions in greater detail later in this manual.

5. Icon Introduction

As you can see, there are many icons in Mario Paint. You can access a desired color, utility, or drawing tool by clicking the left mouse button on the appropriate icon.

| | PAGE |
|--|------|
| ■ ICONS | |
| Undodog..... | 6 |
| Bomb | 6 |
| Pens (Small, Medium, Large) | 7 |
| Airbrush | 7 |
| Erasers..... | 8 |
| Fill Paint Brush..... | 9 |
| Circle, Line, Rectangle Templates..... | 10 |
| Character Stamps..... | 11 |
| Stamp Designer/Editor..... | 12 |
| Copy | 14 |
| Rotate/Flip..... | 14 |
| Drawing Board Color Selection | 16 |
| Framer | 16 |
| Text Stamps..... | 17 |
| Background Music Selection..... | 19 |
| Mouse Speed Selection..... | 19 |
| Music Composition | 20 |
| Animation..... | 22 |
| Save/Load/Coloring Book..... | 26 |
| Gnat Attack..... | 29 |

* Please refer to the pages indicated above for specific information about these icons.

■ The Undodog and Bomb icons appear on each toolbox screen in Mario Paint.



Undodog

Undodog will help you correct a minor mistake by canceling your last action. You will quickly find that this hound is a great friend.



Bomb

Click on the bomb to exit the current area.

Now, let's
start drawing!



6. Drawing Tools

■ Small, Medium, and Large Pens



Small



Medium



Large

Once you've selected a pen tip, you can start drawing by dragging the mouse across the mouse pad with the left mouse button pressed. You'll notice that the cursor changes size when you select a different pen. To select a different color, move the cursor to the palette and click on a desired icon.

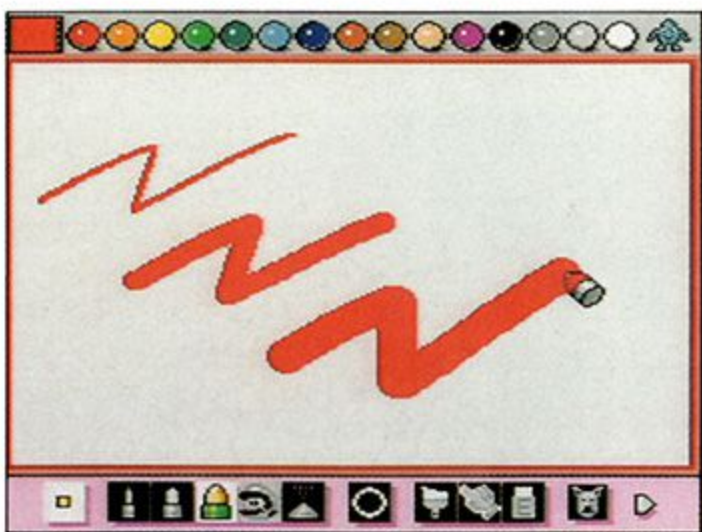

★ **Hint from Professor Paint:**
"Draw slowly with the small pen to avoid drawing broken lines."



■ Airbrush



Airbrush Icon

The Airbrush produces a spray can effect. Like the pens, you use the Airbrush by clicking the left mouse button and dragging the mouse.



■ Erasers



Erasers Icon

Mario Paint contains fifteen (six pens and nine full screen) erasers. The six eraser pens vary in size and allow you to edit a portion of your drawing. These pens use the same motion

as drawing with a colored pen. The full screen erasers accomplish the same task, but use different visual effects.



- Eraser Pens



- Full Screen Erasers



★ **Hint from Professor Paint:**

"If you use Undodog immediately after erasing your drawing, you can see how these erasers work without permanently losing your drawing."



■ Fill Paint Brush



Paint Brush Icon

The Fill Paint Brush gives you the ability to accurately fill in an enclosed area with one color or pattern. To use the Fill Paint Brush, click on the paint brush icon and then select a color or pattern. Next, place the point of the paint brush inside the area that you wish to paint and click the left mouse button.

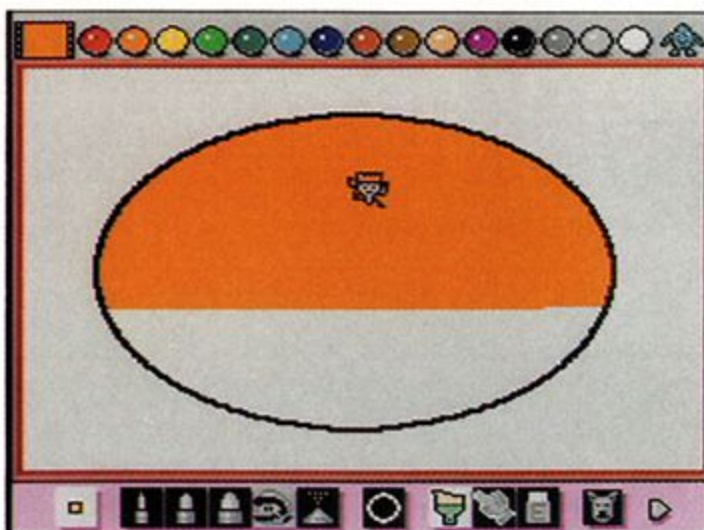

Use this paint brush cursor to fill an enclosed area.



★ Hint from Professor Paint:

"If a line surrounding the painted area is broken, using the Fill Paint Brush will cause the paint to leak outside the line. Don't worry if this happens, though. Click the left mouse button to stop the Fill Paint Brush, click on Undodog to remove the paint from your drawing, fix the broken line, and try again with the Fill Paint Brush."



■ Circle, Line, and Rectangle Templates



Shape Template Icon

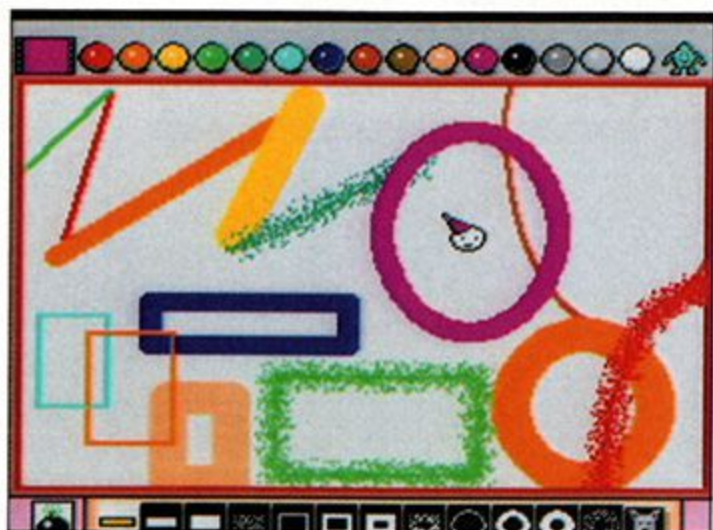

Since it can be difficult to draw perfectly round circles, straight lines, and nice-looking rectangles, Mario Paint contains templates that help you easily create these shapes. To access these templates, click on the circle icon in the main toolbox. On this subscreen, you'll notice that there are four templates for each shape. These four templates use the three pen widths and the airbrush effect to create different line styles.



• Shape Template Menu Bar

To use the templates, click on the icon that represents the shape and line width you want to use. Next, press the left mouse button and slowly drag the mouse. This will draw a rough sketch of the shape. Once you're satisfied with the rough sketch, release the mouse button to make a solid line appear over the sketch.



• Click on one of these icons to create straight lines.

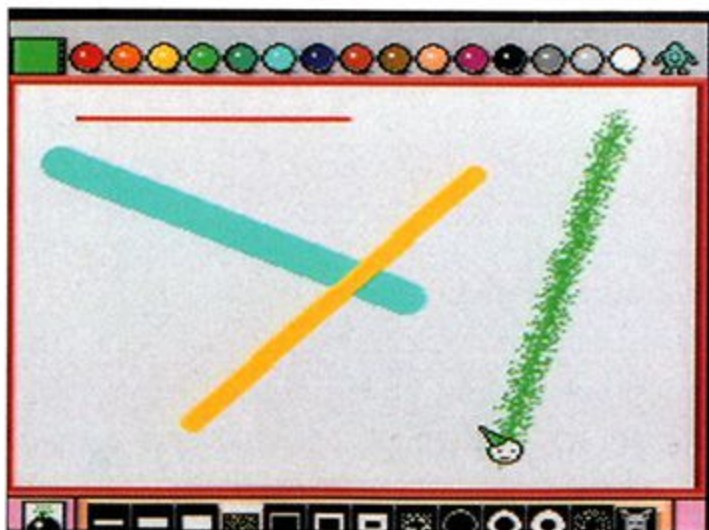



- The rectangle icons will let you design shapes like this.

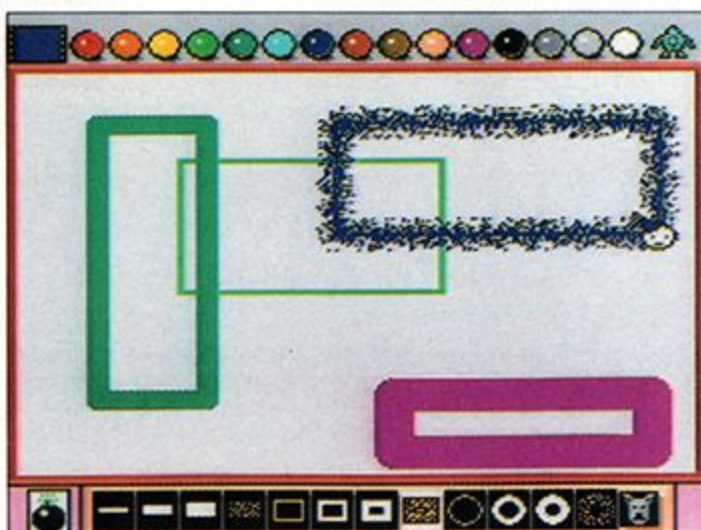

- These icons will help you draw circles of all shapes and sizes.

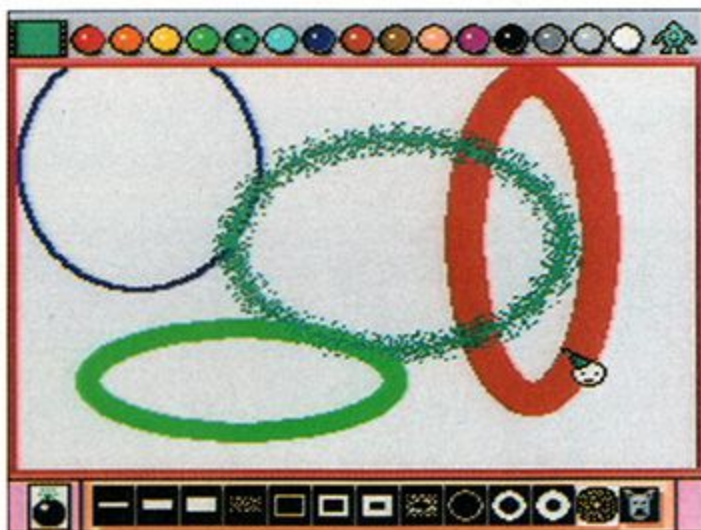

■ Character Stamps



Mario Icon

The Mario icon in the toolbox accesses a tool that can be used to press colors, patterns, and character stamps onto your drawing. You'll find that the stamps will add detail to your drawing without requiring the effort needed to draw the same characters freehand. To access the palette of stamps, click on Mr. Crayon.



Stamp Designer/Editor



Stamp Editor Icon

This function lets you either design your own stamps or edit existing stamps. To create a stamp, choose a color and draw an object using the expanded grid that looks like graph paper.

The X square on the right side of the color palette is a transparent color. For example, if you draw Luigi and surround him with white squares, the white color will show when you press the stamp onto your drawing. If you use the X blocks, the stamp will be cut neatly around the drawing of Luigi.

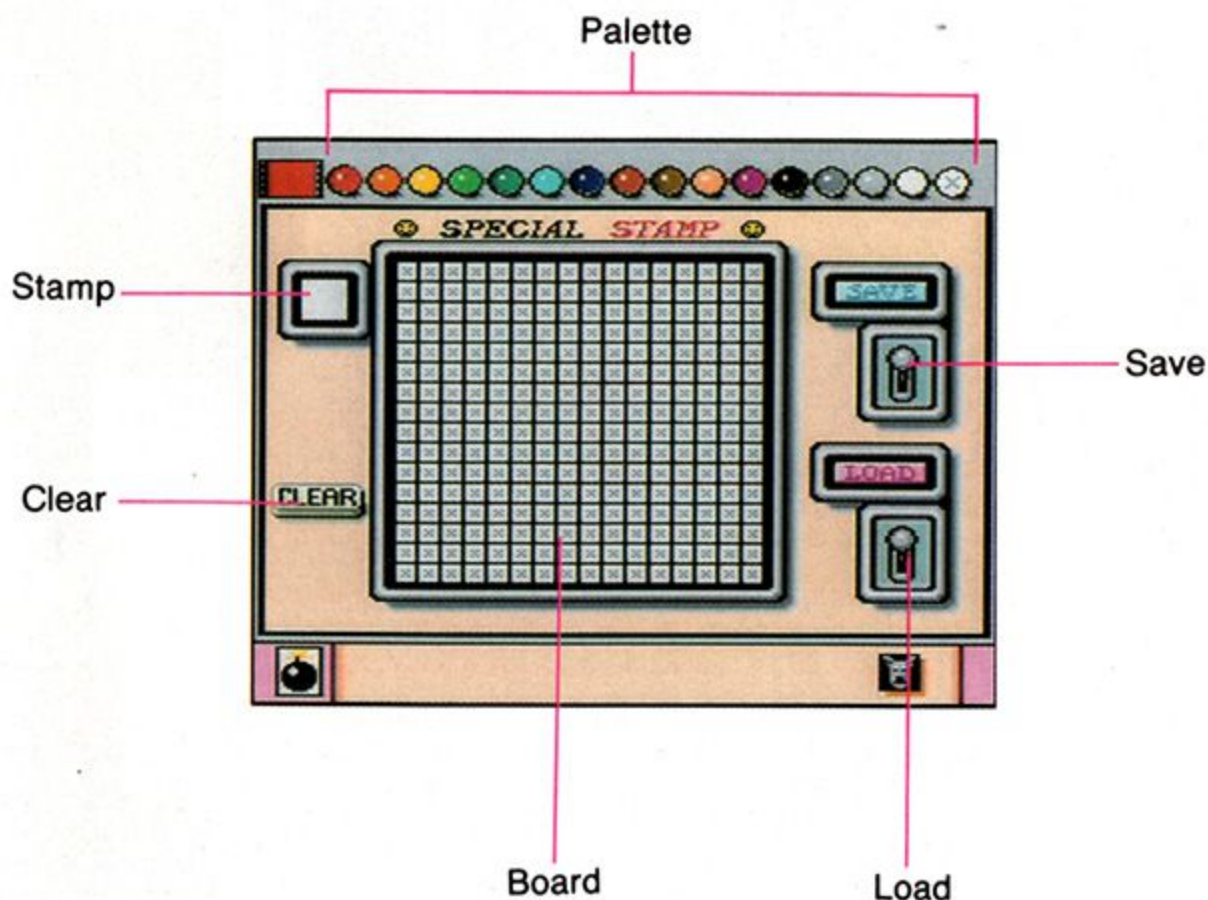
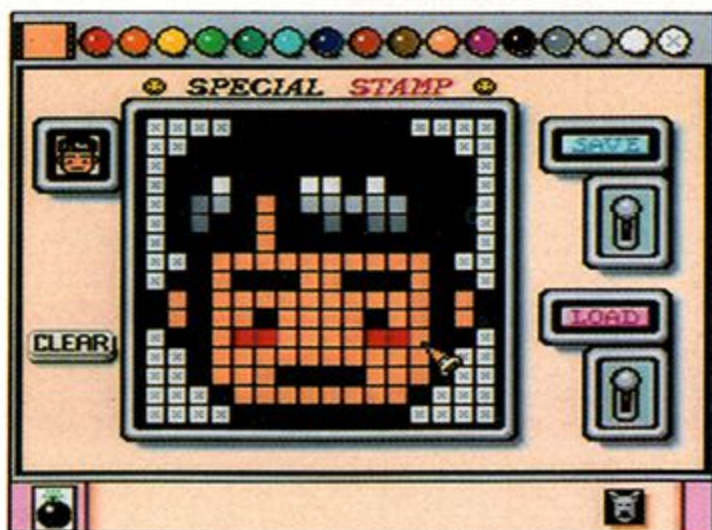

• SAVE

If you want to start again with a clean piece of graph paper, click on the CLEAR button. To save your stamp into your personal stamp database, click on the SAVE lever and then click on one of the empty spaces on the palette. You can have up to 15 stamps stored at once. To replace a stamp you do not wish to keep, simply save a new stamp over an old stamp.

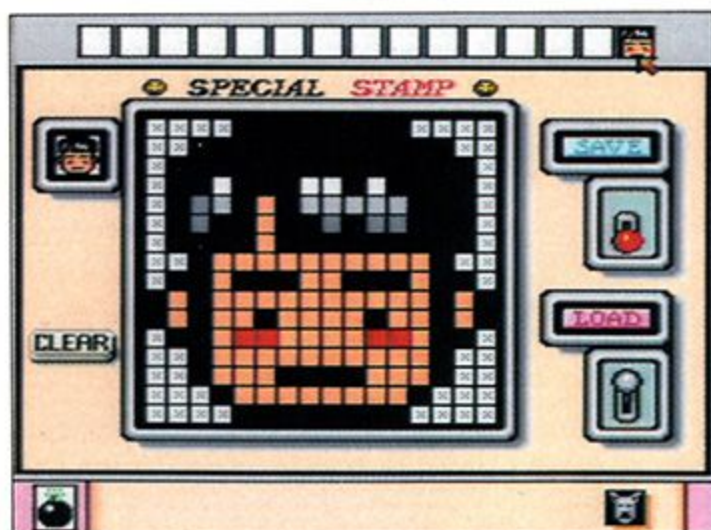
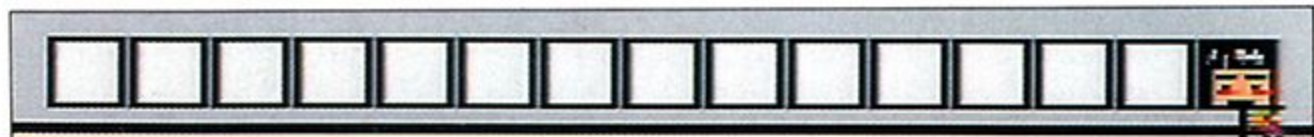

• LOAD

To edit one of the pre-designed stamps, click on the LOAD switch, then click on Mr. Crayon until you find the stamp you wish to change. Next, click on the stamp and edit it using your palette of colors. Once you've finished revising the stamp, be sure to save it to your stamp database. Now you'll have the original stamp and the new stamp ready to use on your background drawing.



★ Hint from Professor Paint:

"The small pen tip makes a line that is two squares wide on the stamp grid. Try making a stamp that only uses one square of the stamp grid. Once you've saved it to your database, click on the Mario icon and draw with this ultra fine dot. This should help you draw lines in areas that require a lot of detail. You can also create an eraser using the same procedure with a single white dot."

■ Copy



Copy Icon

The copy function allows you to capture a section of your drawing and copy it to another area of the drawing board. To use the copy feature, follow these steps:

1. Click on the copy icon. The cursor will transform into a hand.
2. Press the left mouse button and drag the mouse until you've created a frame around the area that you want to copy.
3. Release the mouse button to set the area to be copied. To reset the frame, click on the copy icon.
4. Move the frame to the new area on the drawing board, and click the left mouse button to copy the picture.

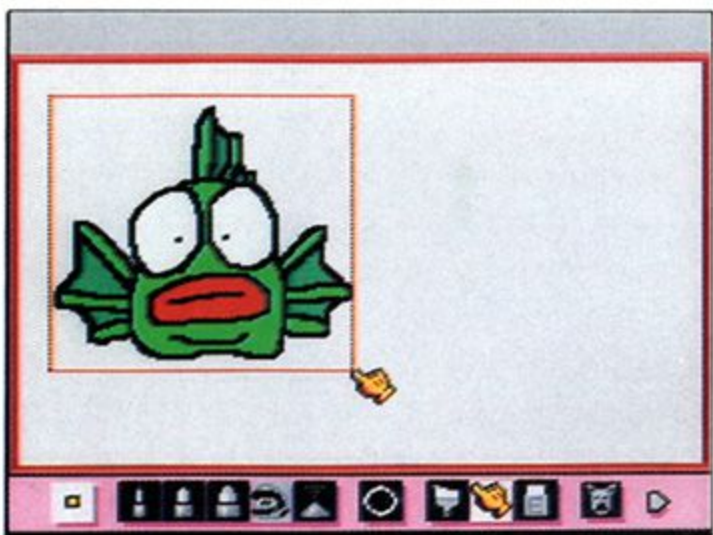
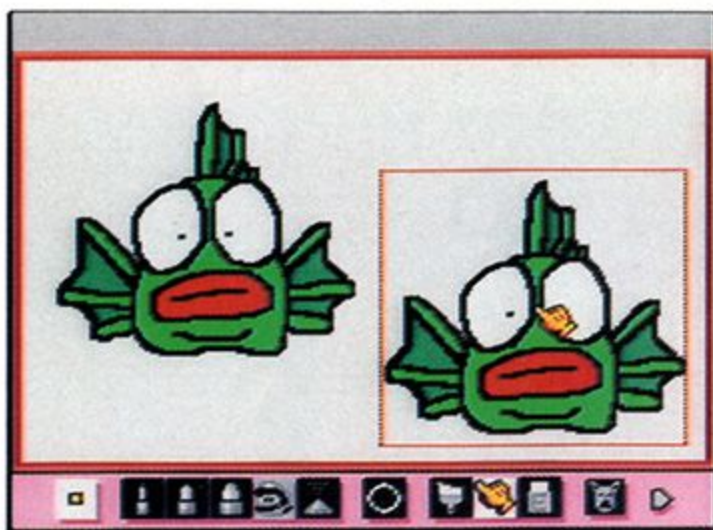

■ Rotate/Flip



Rotate/Flip Icon

When you click on this icon, you'll review four different icons that can be used to change the direction of a stamp or a portion of your drawing. The four icons are described in this section as follows:



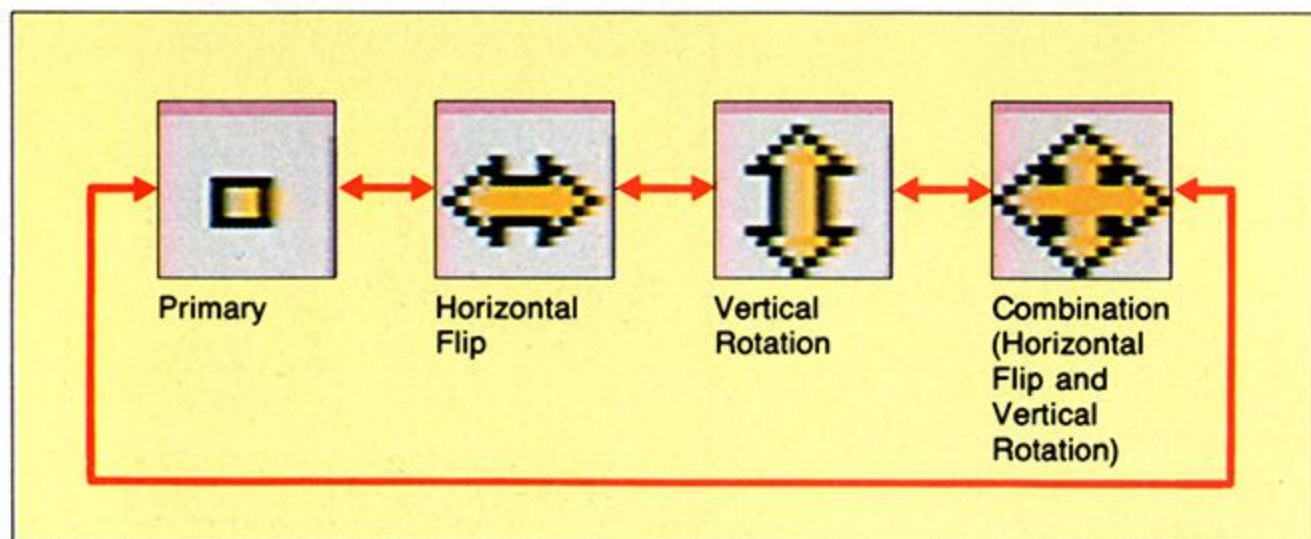

- To use the rotate/flip function with a stamp, select the direction you wish the stamp to face, then click on the stamp's icon. You'll notice that the window on the left side of the palette shows how the stamp will look on the drawing board.



- You can also use the rotate/flip function with the copy feature. Refer to page 14 for details regarding how to use the copy feature.

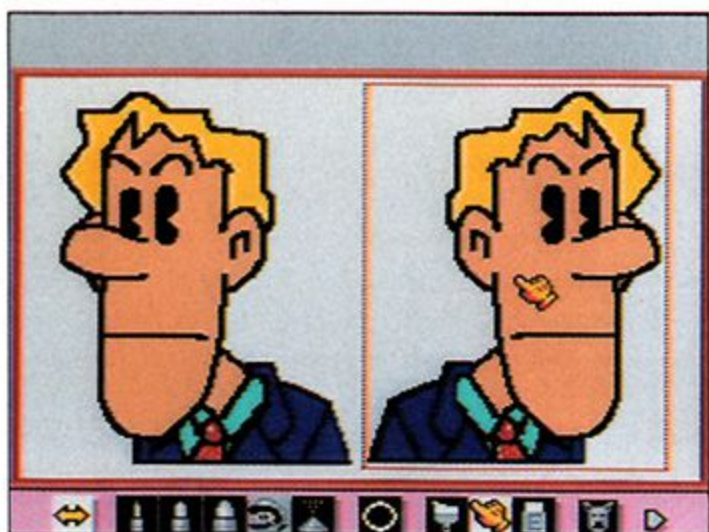

7. Utilities

■ Drawing Board Color Selection



Change Background Icon

This icon allows you to quickly paint a color or pattern on the entire drawing board. Keep in mind, however, that this function will wipe out your drawing like the full screen erasers.

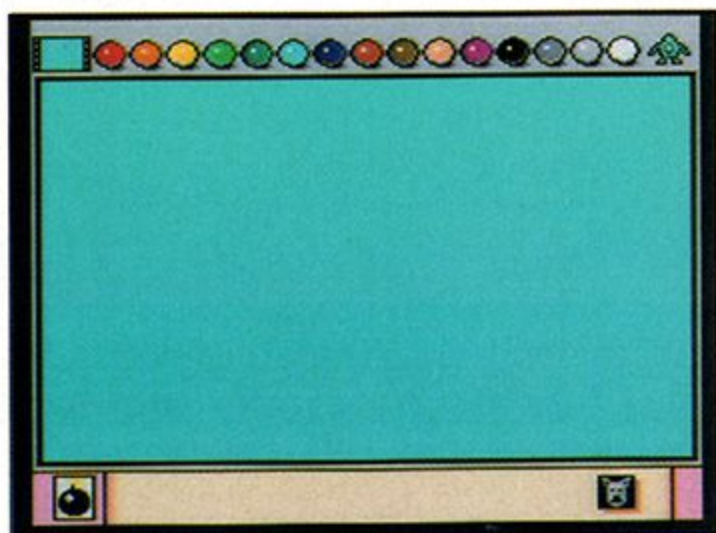

■ Framer



Framer Icon

This icon appears on the utilities menu and inside Animation Land. When you click on the icon, the toolbox and the palette are removed from the screen and replaced with a black frame.



To make the menus reappear, press the left mouse button.

■ Text Stamps



Text Stamp Icon

Mario Paint features upper and lower case letters, numbers, and three types of Japanese characters (explained in greater detail below) that you can add to your collage. In this special

toolbox, there are a few functions that are new. The two squares in the lower left corner change the size of the characters and the tube next to the eraser icon lets you access the color palette, so you can change the color of the characters. Like the standard stamps, you can rotate and flip text stamps.

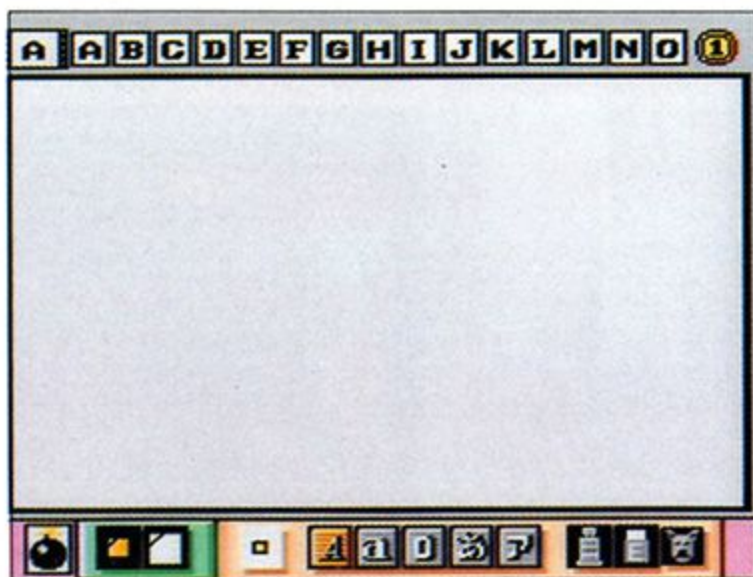

★ Hint from Professor Paint:

"Since Mario Paint is used by artists in North America, Asia and Europe, we have included text stamps that everyone can have fun using. To help you use the Japanese characters that you may not recognize, we've included a chart, so you can have fun with those stamps too. The Japanese language has three writing systems: HIRAGANA (phonetic), KATAKANA (phonetic for foreign words), and KANJI ("Chinese" characters)."

■ HIRAGANA

| | | | | | | | | | | | | | | |
|----|-----|-----|----|----|----|----|----|----|----|----|-----|----|----|----|
| あ | い | う | え | お | か | き | く | け | こ | さ | し | す | せ | そ |
| a | i | u | e | o | ka | ki | ku | ke | ko | sa | shi | su | se | so |
| た | ち | つ | て | と | な | に | ぬ | ね | の | は | ひ | ふ | へ | ほ |
| ta | chi | tsu | te | to | na | ni | nu | ne | no | ha | hi | fu | he | ho |
| ま | み | む | め | も | や | ゆ | よ | ら | り | る | れ | ろ | わ | お |
| ma | mi | mu | me | mo | ya | yu | yo | ra | ri | ru | re | ro | wa | wo |
| ん | | | | | | | | | | | | | | |
| n | | | | | | | | | | | | | | |

■ KATAKANA

| | | | | | | | | | | | | | | |
|----|-----|-----|----|----|----|----|----|----|----|----|-----|----|----|----|
| ア | イ | ウ | エ | オ | カ | キ | ク | ケ | コ | サ | シ | ス | セ | ソ |
| a | i | u | e | o | ka | ki | ku | ke | ko | sa | shi | su | se | so |
| タ | チ | ツ | テ | ト | ナ | ニ | ヌ | ネ | ノ | ハ | ヒ | フ | ヘ | ホ |
| ta | chi | tsu | te | to | na | ni | nu | ne | no | ha | hi | fu | he | ho |
| マ | ミ | ム | メ | モ | ヤ | ユ | ヨ | ラ | リ | ル | レ | ロ | ワ | ヲ |
| ma | mi | mu | me | mo | ya | yu | yo | ra | ri | ru | re | ro | wa | wo |
| ン | | | | | | | | | | | | | | |
| n | | | | | | | | | | | | | | |

■ KANJI

| | | | | | | | | | | | | | |
|---------|-------|--------|-------|-------|-------|--------|-------|------|------|-------|------|-------|-----|
| 一 | 二 | 三 | 四 | 五 | 六 | 七 | 八 | 九 | 十 | 百 | 千 | 万 | 円 |
| ichi | ni | san | shi | go | roku | nana | hachi | kyu | jyu | hyaku | sen | man | yen |
| 1 | 2 | 3 | 4 | 5 | 6 | 7 | 8 | 9 | 10 | 100 | 1000 | 10000 | |
| 日 | 月 | 火 | 水 | 木 | 金 | 土 | 時 | 分 | 秒 | 年 | | | |
| nichi | getsu | ka | sui | moku | kin | do | ji | fun | byo | nen | | | |
| Sun. | Mon. | Tue. | Wed. | Thur. | Fri. | Sat. | hour | min. | sec. | year | | | |
| 東 | 西 | 南 | 北 | 上 | 下 | 左 | 右 | | | | | | |
| higashi | nishi | minami | kita | ue | shita | hidari | migi | | | | | | |
| east | west | south | north | up | down | left | right | | | | | | |

■ Change Background Music



Background Music Icon

When you click on the icon shaped like a treble clef, you can access a control panel that will let you change the background music. In this section, you can choose one of three different tunes. The fourth lever lets you work inside a quiet working environment. Don't be surprised, however, if Undodog's allergies cause him to sneeze occasionally.

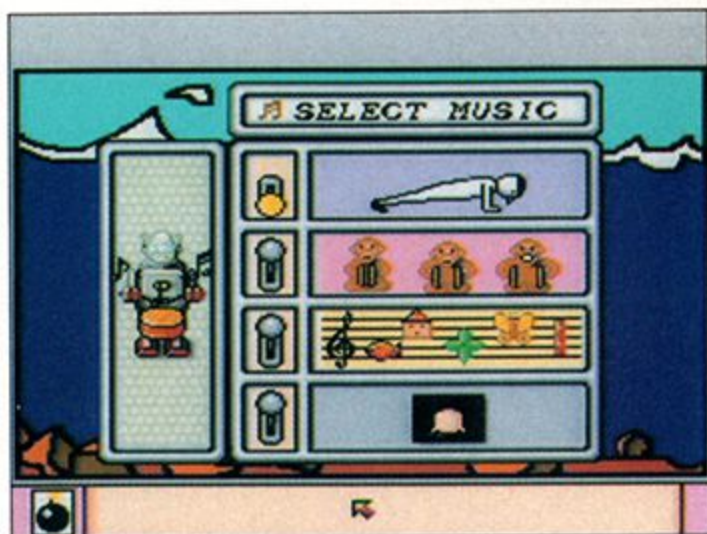

■ Mouse Speed



Mouse Speed Icon

The mouse icon allows you to adjust the speed of the cursor. The slower speed gives you more control, while the faster speed lets you move the cursor quickly across the screen.

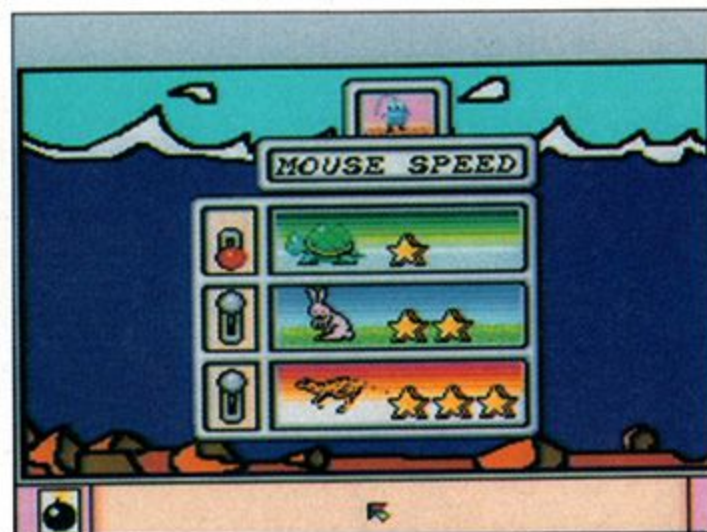

8. Music Composition



Music Composition Icon

When you click on this icon, you will enter the music composition mode where you can write music and add it to your collage. In this area, you can use fifteen sound effects to create a wide range of melodies. The treble clef staff allows you to place notes from low B (below middle C) to high G (above the staff). If you like, you can write chords using as many as three notes on the same line. Throughout this area, there are several icons that you have not used before. The following descriptions should help you become familiar with these new functions:

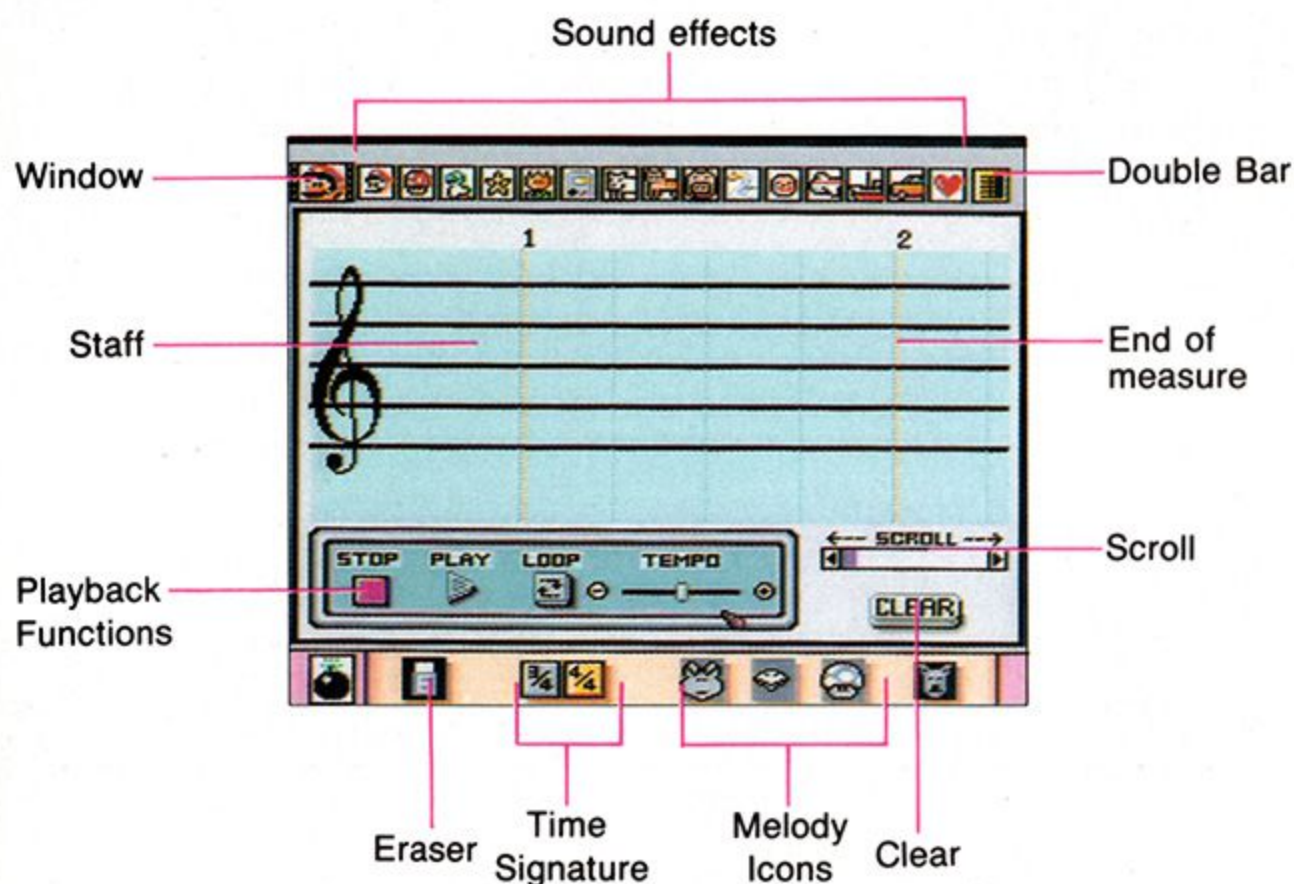
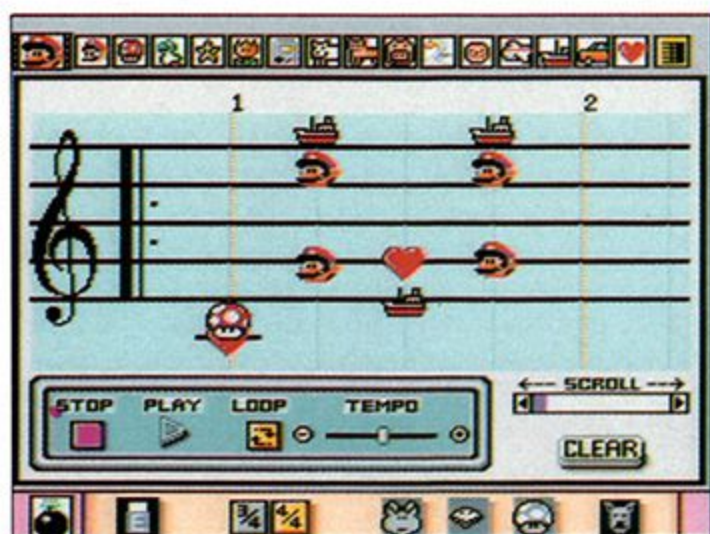

| | |
|-------------|--|
| Eraser: | Removes one note from the music staff |
| 3/4: | Draws measure line after each set of three notes or beats. |
| 4/4: | Draws measure line after each set of four notes or beats. |
| Double Bar: | End of tune |
| Play: | Plays your melody while Mario hops to the beat |
| Stop: | Stops tune before Maio reaches the double bar |
| Loop: | Repeats song from double bar |
| Tempo: | Changes the speed of the tune |
| Scroll: | Advances and reverses music staff screen |
| Clear: | Removes all notes from staff |
| Frog: | Pre-composed melody # 1 |
| Bird: | Pre-composed melody # 2 |
| Toad: | Pre-composed melody # 3 |

• Creating a Tune:

1. Click on one of the character stamps to select a sound effect.
2. Place the stamp on one of the vertical lines on the staff. Again, you can have one, two, or three notes on one beat (vertical line).
3. Once you've placed the notes where you want them, click on the double bar and place it at the end of your tune.
4. Now you're ready to click on the PLAY icon and listen to your composition.
5. If you'd like, you can add the LOOP feature or change the TEMPO.

You can use the pre-composed melodies if you wish to quickly add a tune to your collage. You can also edit these songs to make a variation of a familiar theme.

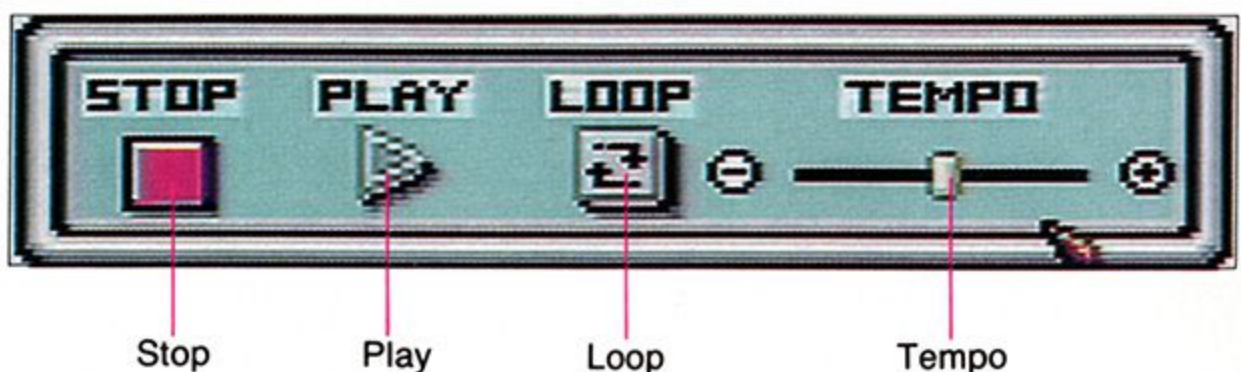

9. Animation



Animation Icon

Now that you're familiar with the drawing tools and basic utilities, you're ready to create an animated sequence! To enter Animation Land, click on the icon with the jump-roping icon. Once you're inside Animation Land, you'll see the SIZE, PATH, ANIMATION icons. Later in this section, we will explain each of these areas in greater detail.

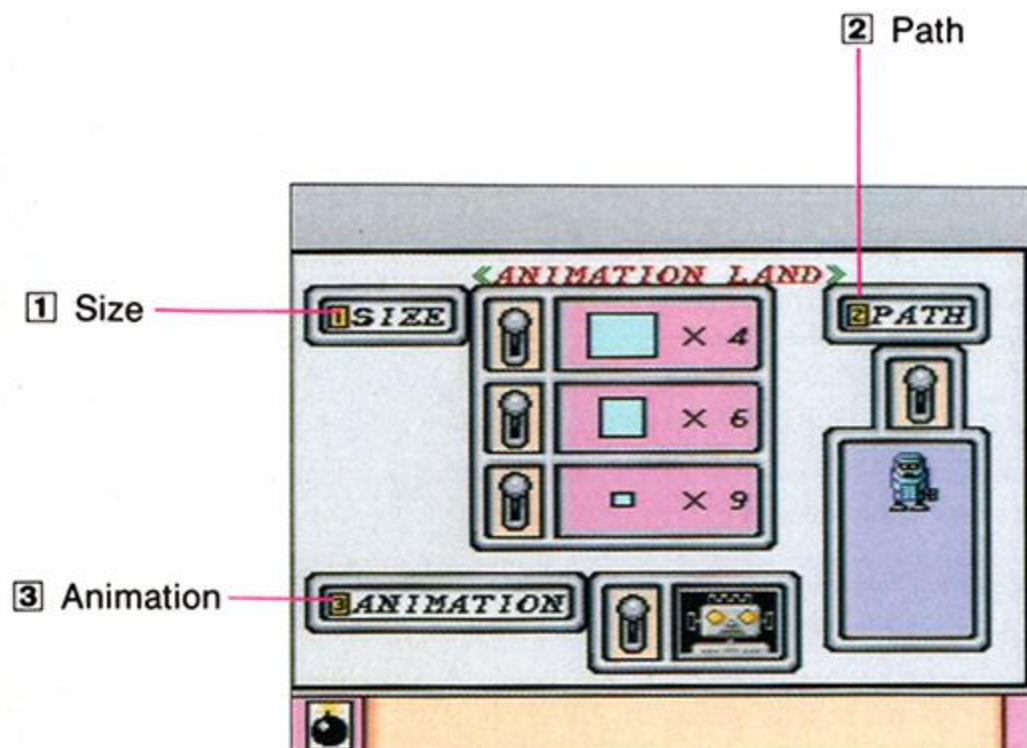

1 Size

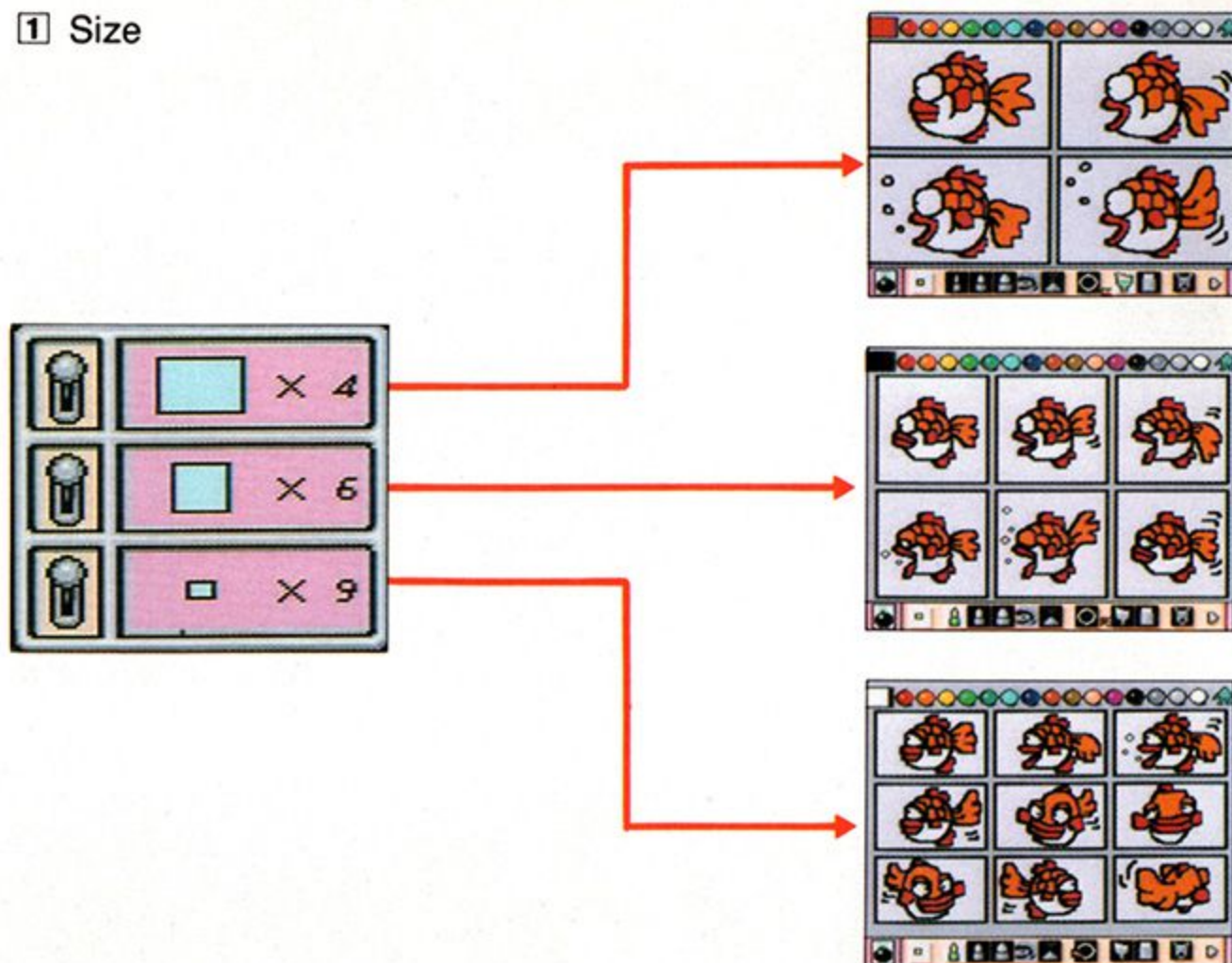

In Mario Paint, you can design four, six, or nine frame animations. With four frame animations, you can animate up to 25% of the drawing board, however, the animation won't be very complicated. Six frame animations allow you to create an animated sequence that's more complex, but each cell is smaller than the four frame size. Even though you're only working with a small portion of the original drawing board in the nine frame section, with patience and practice, you can create cartoon-like animation.

• Creating an Animated Character

Now select the four frame size, so you can create a simple animated sequence. When creating an animated character, you have the option of drawing the character freehand or using a stamp. Mario Paint has six character stamps pre-designed for animation. Click on the Mario icon, and then click on Mr. Crayon until you see these Super Mario Bros. characters. You'll notice that these characters each have at least two stamps that can be used to set up animation. In this case however, we'll use a freehand drawing of a large fish swimming across the screen.

Since we want the animation to move smoothly, we'll need to use the copy feature to move the fish's body to the other cells. On the second page of the animation toolbox, you should recognize five of the six icons. The open hand icon is also a copy feature, but this feature copies one entire animation cell to another cell. Use the open hand icon to copy the fish to each of the three remaining cells. Now we're ready to finish drawing the movements of the fish's tail. Once you've completed your animation sequence, click on the bomb and return to the main Animation Land screen.

2 Path

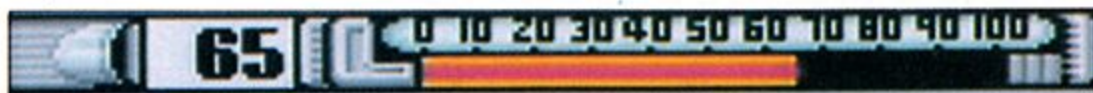

To set a path for your character to follow, click on the path lever. Next, click the left mouse button and drag the mouse along the desired path. In this mode, the character will not only follow the path of the mouse, but also the speed that you move the mouse across the pad. Your character can follow any path until the counter reaches 100. If you would like to reset and start a new path, click on the CLEAR button. Return to Animation Land once you've created a path you'd like to use.

3 Animation



Click on this icon to play your musical composition.

Now when you click on the animation icon in Animation Land, your character will move through your drawing following the path you created in the last area. The SPEED function allows you to increase or decrease the animation rate. In this example, a faster rate would make the fish's tail and mouth move faster. If you click on the piano keyboard icon, you will add your background music from the music composition mode to the collage. (Refer to page 20 for details about the music composition mode.)

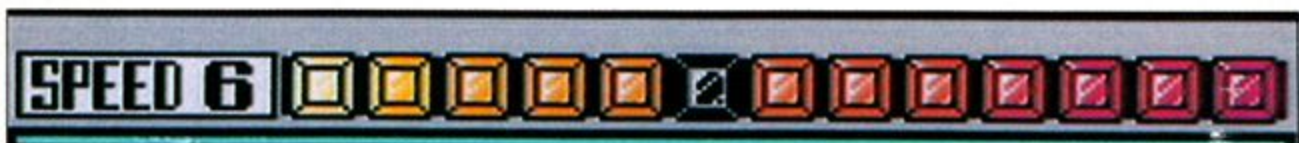

10. Save/Load/Coloring Book

The robot icon accesses an area that is used to save and load a collage. Mario Paint's Electronic Coloring Book is also located in this section.



Save · Load Icon

Mario mark

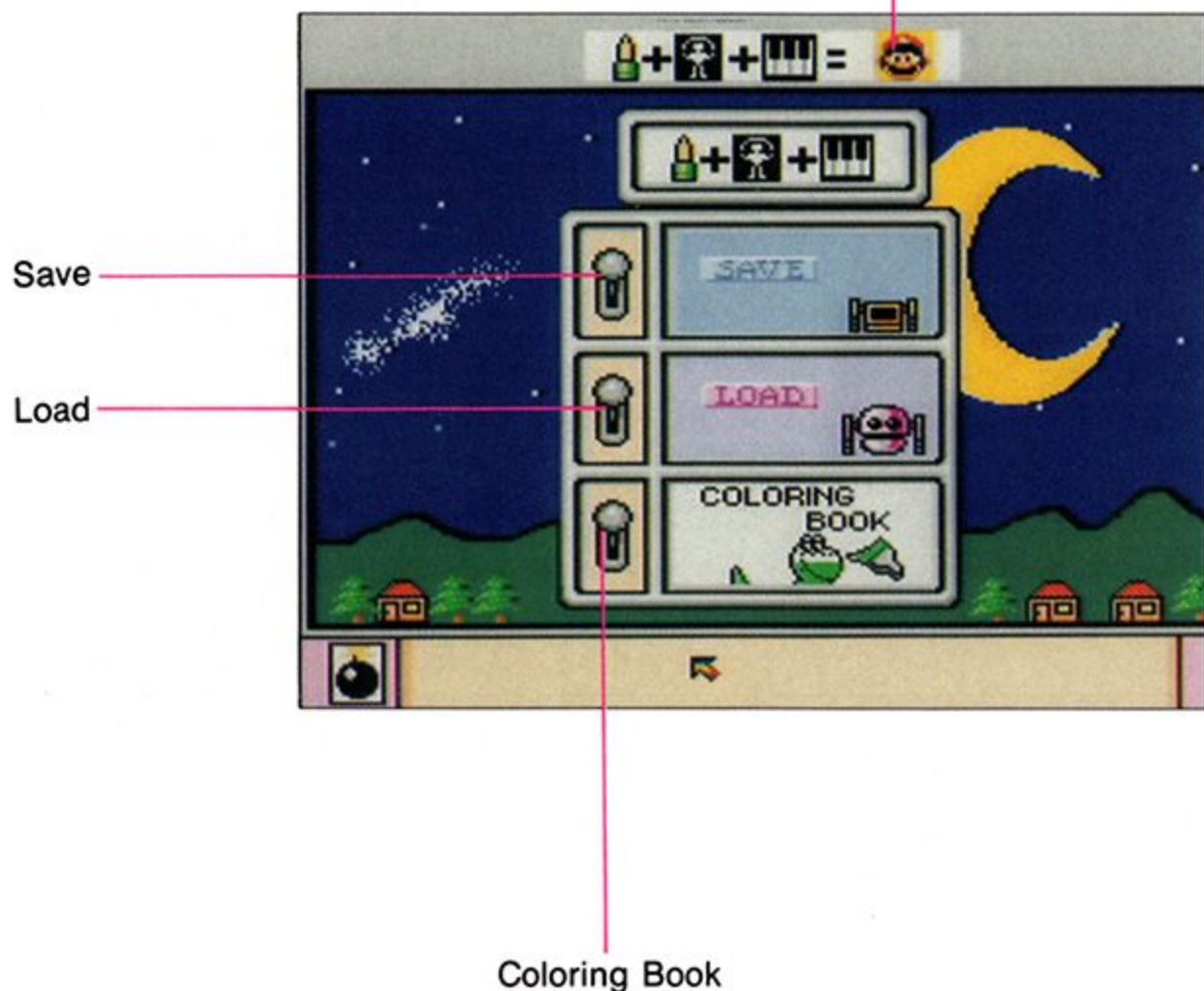

■ SAVE

You can save one collage at any time. If there is a flashing Mario face above the save/load control panel, then there is already a collage saved in memory. To save a drawing, animation, and music combination, click on the save lever, then click on the start button when the big robot appears on the screen.

Once the Super NES has finished saving your collage, the Mario icon will appear at the top of the screen.



This Mario icon will appear once you've successfully saved your collage.

■ LOAD

To load a saved masterpiece, follow the same procedure, except click on the load lever rather than the save lever. The load switch will only work if there is a Mario icon above the save/load control panel.



■ COLORING BOOK

The coloring book features four pre-drawn background screens that can be colored and edited. You can also add animation and music to these screens. The first screen features a couple of pals you might recognize. The second page of the coloring book gives you a zoo full of animals to color. The third screen has a greeting card that lets you take advantage of the copy function. The fourth coloring book screen is an underwater scene that contains many animation possibilities.

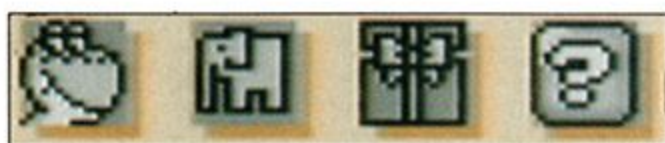

Switch



Click on this icon to edit this background drawing.

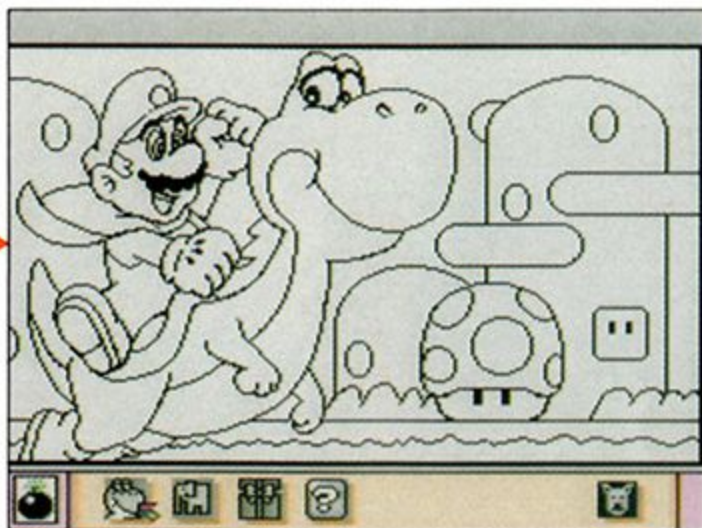

11. Gnat Attack



Gnat Attack is a training game that helps inexperienced mouse users establish coordination with the mouse. To play, you need to swat the various types of insects before they sting your hand. To swat the flies, move the hand over the bug and click the left mouse button. Once you've swatted 100 insects, you'll receive a challenge from King Watinga. Even though this is a training game, expert mouse users will love this change of pace.

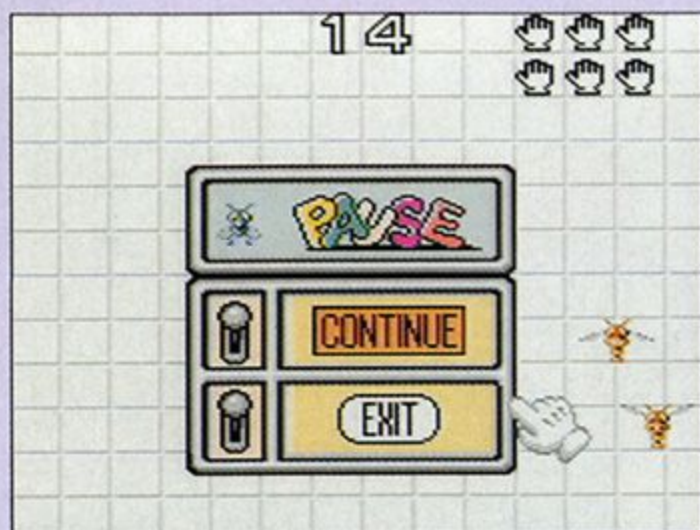
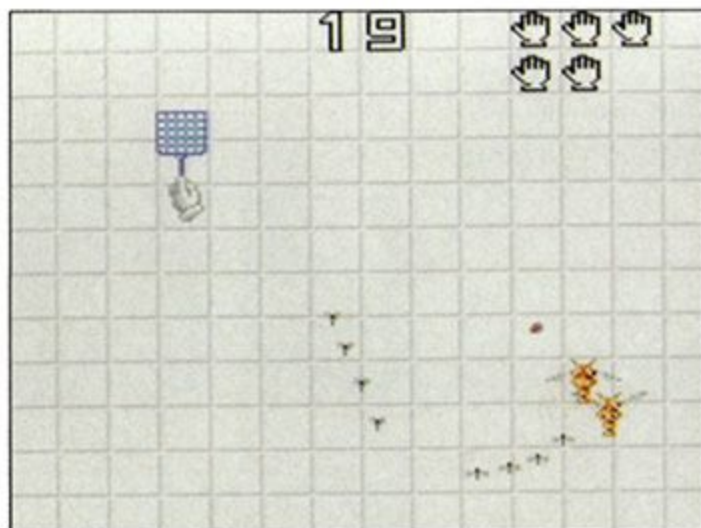

To exit or pause the game, click the right mouse button.

■ A FINAL NOTE FROM PROFESSOR PAINT:

"Now that you know how to create with Mario Paint, here is some information that will help you record your collages to video. Using your VCR, you can record hours of artistic fun and display your talent to family and friends. The following instructions will help you connect your Super NES to your VCR and television.



Note: On the following page, there are two sets of instructions. You do not need to follow method one **and** method two. Choose the set of instructions that match your current VCR and television configuration."

Method One: Using the Super NES audio/video cable and a standard audio/video cable

1. Connect the Super NES audio/video cables to the audio input and video input ports on your VCR. Insert the grey plug on the audio/video cables into back of the Super NES.
2. Using a standard audio/video cable, connect one end of the cable into the audio and video output ports on the VCR and the other end of the cables to the audio and video input ports on your television. Skip to step three in method two.

Method Two: Using the Super NES RF switch and a standard coaxial cable

1. Connect the short cable from your Super NES RF switch into the VHF input coaxial post on your VCR. Insert the end of the long cord on the RF switch into the Super NES.
2. Using a standard coaxial cable, connect one end of the cable into the VHF output post on your VCR and the opposite end of the cable into the VHF input post on the back of your TV.
3. Now turn on the power on your VCR, television, and Super NES. Once you find the channel or line that shows your Super NES game screen on the TV, you're ready to record. Since there are many makes and models of video recorders with many different functions and features, you may still experience difficulty making the game screen appear after following these instructions. If so, please call 1-800-255-3700 for further assistance.

12. Glossary

- Airbrush:** An object that uses compressed air to spray paint onto a drawing surface.
- Animation:** The process of creating the illusion of motion using cartoon drawings.
- Click:** The action indicated when a mouse button is pressed.
- Collage:** A combination of a background drawing, an animated sequence, and a musical composition.
- Cursor:** An on-screen indicator (pointer) that identifies the location of the next selection.
- Double Bar:** A double vertical line that appears on a musical staff and indicates the end of a main section of a musical composition.
- Drag:** The action indicated when the mouse is moved across the mouse pad.
- Frame:** A single exposure in an animated sequence.
- Icon:** A small picture that labels an item or function using graphics rather than text.
- Palette:** A range of colors that an artist has available to use.
- Template:** A pattern that is used as a guide to accurately draw a shape or character.
- Tempo:** The relative speed that a musical composition is played.



WARRANTY AND SERVICE INFORMATION**90-DAY LIMITED WARRANTY****HARDWARE*, ACCESSORIES, GAME PAKS ("PRODUCT")**

*HARDWARE ONLY: TO EXPEDITE AUTHORIZATION OF ANY REQUIRED WARRANTY WORK, WE RECOMMEND THAT YOU COMPLETE AND RETURN YOUR WARRANTY CARD WITHIN 10 DAYS OF PURCHASE (OR RECEIPT AS A GIFT).

90-DAY LIMITED WARRANTY

Nintendo of America Inc. ("Nintendo") warrants to the original purchaser that this product shall be free from defects in material and workmanship for a period of 90 days from the date of purchase. If a defect covered by this warranty occurs during this 90-day warranty period, Nintendo will repair or replace the defective product or component part, at its option, free of charge.

**WARRANTY SERVICE OR
REPAIR/SERVICE AFTER EXPIRATION OF WARRANTY**

To receive this warranty service or to receive service after warranty expiration:

1. **DO NOT** return your product to the retailer.
2. Please call the **NINTENDO WORLD CLASS SERVICE[®]** Center Consumer Assistance Hotline at: **1-800-255-3700**. Our hours of operation are from 4:00 am to Midnight, Pacific Time, Monday through Saturday, and from 6:00 am to 7:00 pm, Pacific Time on Sundays (times subject to change). If the Nintendo Service Representative is unable to solve the problem over the telephone, you will be referred to the nearest **AUTHORIZED NINTENDO WORLD CLASS SERVICE[®]** Center for prompt, professional warranty service or repair and replacement components. You may also refer to your yellow pages directory under the heading of *Video Games - Service & Repair*, for the nearest location.

To satisfy the needs of our customers, Nintendo maintains a professional network of **AUTHORIZED NINTENDO WORLD CLASS SERVICE[®]** Centers located in major metropolitan areas and also offers express factory service. In some instances it may be necessary to ship the complete product, **FREIGHT PREPAID AND INSURED FOR LOSS OR DAMAGE** to the nearest service location.

This warranty shall not apply if the product has been damaged by negligence, accident, unreasonable use, commercial use, modification, tampering, or by other causes unrelated to defective materials or workmanship. This warranty shall not apply if any product serial number has been altered, defaced, or removed.

WARRANTY LIMITATIONS

ANY APPLICABLE IMPLIED WARRANTIES, INCLUDING WARRANTIES OF MERCHANTABILITY AND FITNESS FOR A PARTICULAR PURPOSE, ARE HEREBY LIMITED TO NINETY DAYS FROM THE DATE OF PURCHASE AND ARE SUBJECT TO THE CONDITIONS SET FORTH HEREIN. IN NO EVENT SHALL NINTENDO BE LIABLE FOR CONSEQUENTIAL OR INCIDENTAL DAMAGES RESULTING FROM THE BREACH OF ANY EXPRESS OR IMPLIED WARRANTIES.

The provisions of this warranty are valid in the United States and Canada only. Some states/provinces do not allow limitations on how long an implied warranty lasts or exclusion of consequential or incidental damages, so the above limitations and exclusions may not apply to you. This warranty gives you specific legal rights, and you may also have other rights which vary between states/provinces.

**NEED HELP WITH INSTALLATION, MAINTENANCE
OR SERVICE? CALL 1-800-255-3700.**



Nintendo of America Inc.
P.O. Box 957, Redmond, WA 98073-0957 U.S.A.

PRINTED IN JAPAN